

FEATURES

- Input for thermocouples type K, J, R, S and T
- Unit of measure configurable in °C or °F
- Zero and Span values configurable by DIP-switches
- 4 to 20 mA "voltage linear" output on current loop
- Good accuracy and performance stability
- EMC compliant – CE mark
- DIN rail mounting in compliance with EN-50022 and EN-50035



GENERAL DESCRIPTION

The transmitter DAT 2045 is designed to provide on its output a 4+20 mA current loop signal linear and proportional with the value of voltage generated from the thermocouple connected to its input.

The DAT 2045 doesn't execute the linearisation of the input signal; this feature allows to use the transmitter with acquisition systems with an internal linearisation software.

The user can program the input ranges by the proper DIP-switches available after opening the suitable door located on the side of device (see "Input range table" section).

The regulation of Zero and Span values is made by the ZERO and SPAN potentiometers located on the top of device.

It is housed in a plastic enclosure of 12.5 mm thickness suitable for DIN rail mounting in according to EN-50022 and EN-50035 standards .

OPERATIVE INSTRUCTIONS

The transmitter DAT 2045 must be powered by a direct voltage included in the 10 V to 30 V range. The power supply must be applied between the terminals R (+V) and P (-V), or alternatively between the terminals Q (+V) and O (-V).

The 4+20 mA output signal is measurable in series to the power loop as shown in the section "Power supply/output connections"; "Rload" is the input impedance value of the instruments located on the current loop; for a correct measure, it is recommended that the maximum value of "Rload" must be calculated as function of the power supply value (refer to the section " Load characteristic ").

The input connections must be made as shown in the section "Input connections".

The thermocouple sensor must be connected between the terminals L (+TC) and I (-TC); in case of use of a shielded cable, connect the shield to the terminal I .

The configuration of input ranges values is made by DIP-switches (refer to the section "Input range table").

After the transmitter configuration, it is necessary to calibrate it using the ZERO and SPAN regulations; this operation is illustrated in the section "DAT 2045: Configuration and calibration".

This operation can be made on field refer to a calibrated thermometer or using a simulator of thermocouple; in case of use of simulator of thermocouple with internal CJC, the value of voltage corresponding to the ambient temperature must be subtracted from the input voltage .

To install the device refer to the section "Installation instructions".

TECHNICAL SPECIFICATIONS (Typical @ 25 °C and in nominal conditions)

Input	
Sensor type	Thermocouple type J, K, R, S and T
Zero programmability	Programmable from -50 up to 50 °C or from - 58 up to 122 °F
Span programmability	Thermocouple type K: from 100 up to 1370 °C or from 210 up to 2500 °F Thermocouple type J: from 100 up to 950 °C or from 210 up to 1740 °F Thermocouple type R: from 700 up to 1760 °C or from 1200 up to 3200 °F Thermocouple type S: from 700 up to 1760 °C or from 1290 up to 3200 °F Thermocouple type T: from 100 up to 450 °C or from 210 up to 840 °F
Input impedance	≥ 10 MΩ
Line resistance influence	0.2 μV / Ω
Output	
Signal type	4 + 20 mA on current loop
Burnout condition	Positive out of scale (> 20 mA)
Maximum output signal	30 mA
Load resistance (Rload)	see "Load characteristic"
Response time (from 10 to 90 % of f.s.)	500 ms
Warm-up time	3 minutes
Performances	
Calibration error	> of ± 0.1 % of f.s. or 0.2 °C
Linearity error (*)	± 0.05 % of f.s.
Cold Junction Compensation	± 0.5 °C
Thermal drift	0.02 % of f.s./°C (for Span > 300 °C / 500 °F)
Power supply voltage (**)	10 + 30 Vdc
Electromagnetic Compatibility (EMC) (for industrial environments)	Immunity: EN 61000-6-2; Emission : EN 61000-6-4
Operating temperature	-20 + 70 °C
Storage temperature	-40 + 85 °C
Relative humidity (non cond.)	0 + 90%
Maximum Altitude	2000 m
Installation	Indoor
Category of installation	II
Pollution Degree	2
Weight	approx. 90 g
Mechanical Specifications	
Material	Self-extinguish plastic
IP Code	IP20
Wiring	wires with diameter 0.8÷2.1 mm ² /AWG 14-18
Tightening Torque	0.8 N m
Mounting	in compliance with DIN rail standard EN-50022 and EN-50035

(*) inclusive of hysteresis and power supply variation.

(**) internally protected against polarity reversion.

DAT 2045: CONFIGURATION & CALIBRATION

- 1) Calculate the difference between the maximum and the minimum value of the input range (Span).
- 2) Refer to the "Input ranges table", find the thermocouple in use and determine in the column "PROG SPAN" where the calculated value is included. Determine in the column "PROG ZERO", the range of value where the zero scale value is included. In the side, is shown the relative DIP-switches configuration.
- In the correspondent lines is shown as to set the DIP-switches .
- 3) Set the DIP-switches as indicated .
- 4) Connect on input a simulator of thermocouple.
- 5) Set the simulator at the minimum temperature.
- 6) By the ZERO potentiometer calibrate the output at 4 mA .
- 7) Set the simulator at the maximum temperature.
- 8) By the SPAN potentiometer calibrate the output at 20 mA .
- 9) Repeat the operation from the step 5 to the step 8 until the output value will be correct (3 attempts typically required).

Configuration ex. : 0/400 °C Tc "K"

Span => 400°C;

Input switches configuration (DSI) : On, On, On, On.

INPUT RANGES TABLE

THERMOCOUPLE K PROG. SPAN	SWITCH			THERMOCOUPLE K PROG. ZERO	SW 4
	1	2	3		
100÷150°C (210÷300 °F)	●	●		- 50 ÷ - 10°C (-58 ÷ 14 °F)	
150÷470°C (300÷870 °F)	●	●	●	-10 ÷ 50 °C (14 ÷ 122 °F)	●
470÷1370°C (870÷2500 °F)	●		●		

THERMOCOUPLE J PROG. SPAN	SWITCH			THERMOCOUPLE J PROG. ZERO	SW 4
	1	2	3		
100÷150°C (210÷300 °F)		●	●	- 50 ÷ - 10°C (-58 ÷ 14 °F)	
150÷350°C (300÷660 °F)		●	●	-10 ÷ 50 °C (14 ÷ 122 °F)	●
350÷600°C (660÷1110 °F)		●	●		
600÷950°C (1110÷1740 °F)			●		

THERMOCOUPLE R PROG. SPAN	SWITCH				The programming of the Zero is not necessary; it can be adjusted from -50 up to 50 °C by the Zero potentiometer.
	1	2	3	4	
700÷800°C (1290÷1470 °F)		●		●	
800÷1760°C (1470÷3200 °F)		●	●	●	

THERMOCOUPLE S PROG. SPAN	SWITCH				The programming of the Zero is not necessary; it can be adjusted from -50 up to 50 °C by the Zero potentiometer.
	1	2	3	4	
700÷800°C (1290÷1470 °F)		●		●	
800÷1760°C (1470÷3200 °F)		●	●	●	

THERMOCOUPLE T PROG. SPAN	SWITCH				The programming of the Zero is not necessary; it can be adjusted from -50 up to 50 °C by the Zero potentiometer.
	1	2	3	4	
100÷130°C (210÷260 °F)		●		●	
130÷450°C (260÷840 °F)		●	●	●	

● = DIP SWITCHES: " ON"

LOAD CHARACTERISTIC

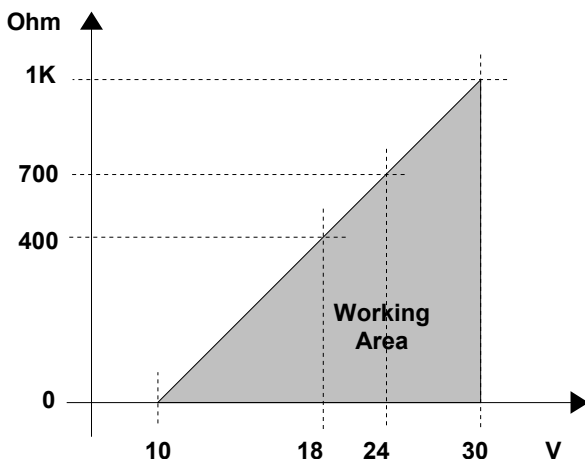

INSTALLATION INSTRUCTIONS

The device DAT 2045 is suitable for DIN rail mounting.

It is necessary to install the device in a place without vibrations . Moreover, it is recommended to use shielded cable to connect signals and to avoid routing conductors near power signal cables.

CONNECTIONS DAT 2045

INPUT CONNECTIONS

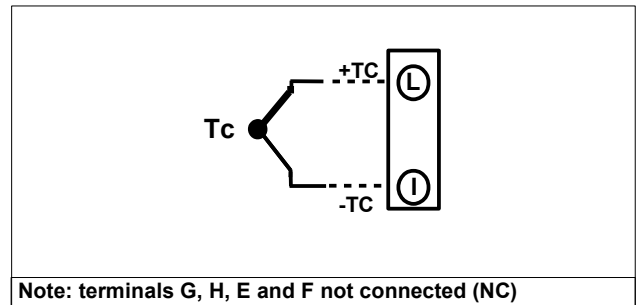

POWER SUPPLY/OUTPUT CONNECTIONS

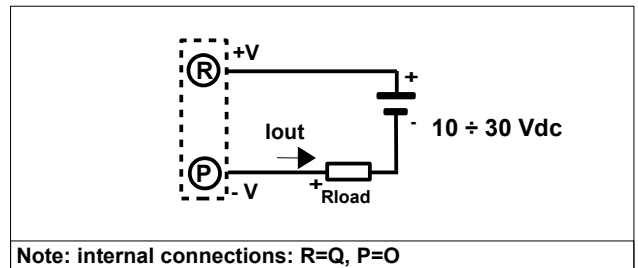

Terminals N and M are not connected (NC) .

DIMENSIONS (mm) & SETTINGS

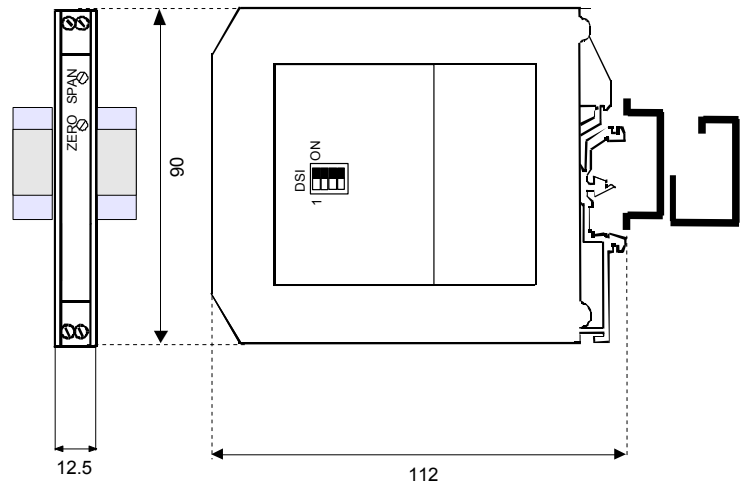

HOW TO ORDER

The DAT 2045 is supplied regulated as requested on the order. In case of the configuration is not specified, the parameters must be set by the user.

ORDER CODE EXAMPLE: DAT 2045 - K - 0÷1200 °C

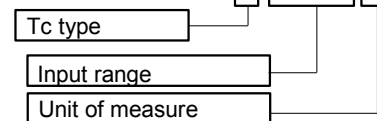

The symbol reported on the product indicates that the product itself must not be considered as a domestic waste. It must be brought to the authorized recycle plant for the recycling of electrical and electronic waste. For more information contact the proper office in the user's city , the service for the waste treatment or the supplier from which the product has been purchased.