

Modbus TCP/IP server 16 Digital Inputs DAT 8148



FEATURES

- Interface Ethernet 10/100 Base-T, Modbus TCP Server
- N.16 Digital inputs
- Built-in Web server to acquire the digital inputs state via web browser
- Remotely programmable
- Connection by removable screw-terminals
- LED signalling for Link/Act Ethernet, power supply
- LED signalling for digital inputs state
- Galvanic isolation on all the ways
- CE mark
- In compliance to EN-50022 DIN rail mounting



GENERAL DESCRIPTION

The device DAT8148 is a Modbus TCP server unit with 16 digital input channels.

For the digital inputs are available up to 4 counters 32 bit with measure of frequency up to 300 Hz.

The Ethernet interface allows to read and write in real time the value of device's internal registers.

The built-in Web Server allows the remote visualization and acquisition of the digital inputs state and access to and configure the main Ethernet parameters via web browser. The device is also configurable by the software *Dev9K*, a free IDE developed by DATEXEL.

The device realizes a full electrical isolation between the lines, introducing a valid protection against the effects of all ground loops eventually existing in industrial applications. The LEDs of signalling of Ethernet activity, input and power supply allow a direct monitoring of the system functionality. The connection is made by removable screw-terminals (inputs and power supply) and RJ45 plug (Ethernet).

The DAT8148 is in compliance with the Directive UL 61010-1 for US market and with the Directive CSA C22.2 No 61010-1 for the Canadian market.

The device is housed in a rough self-extinguishing plastic enclosure which, thanks to its thin profile of 22.5 mm only, allows a high density mounting on EN-50022 standard DIN rail.

USER INSTRUCTIONS

Before to install the device, please read the "Installation Instruction" section.

To configure the device use the INIT modality. Connect the terminal INIT to the terminal -V (refer to the User Guide of the device).

Connect power supply, Ethernet and digital inputs as shown in the "Wiring" section. The LEDs state depends on the working condition of the device: see the "Light Signalling" section to verify the device working state. To perform configuration and calibration operations, read the instructions in the User Guide of the device.

To simplify handling or replacing of the device, it is possible to remove the wired terminals even with the device powered.

TECHNICAL SPECIFICATIONS (Typical @ 25 °C and in the nominal conditions)

In compliance with Ethernet IEEE 802.3		DIGITAL INPUTS		POWER SUPPLY	
Network interface Protocol	Ethernet 10/100Base-T Modbus TCP	Channels	16	Power supply voltage	10 .. 30 Vdc
Max. cable length	100 meters	Input voltage (bipolar)		Reverse polarity protection	60 Vdc max
Number of socket	up to 16	OFF state	0 ÷ 3 V	Current Consumption	220 mA max
		ON state	10 ÷ 30 V	ISOLATION	
		Impedance	4.7 KΩ	Power Supply / Ethernet	1500 Vac, 50 Hz, 1 min
		Sample time	5 ms	Inputs / Power supply	1500 Vac, 50 Hz, 1 min
		Number of counters	4	Inputs / Ethernet	1500 Vac, 50 Hz, 1 min
		Counters register bit-length	32 bit	Inputs / Inputs	1500 Vac, 50 Hz, 1 min
		Counters frequency	up to 300 Hz	ENVIRONMENTAL CONDITIONS	
		Minimum pulse width	1 ms	Operative Temperature	-10°C .. +60°C
				Storage Temperature	-40°C .. +85°C
				Humidity (not condensed)	0 .. 90 %
				Maximum Altitude	2000 m
				Installation	Indoor
				Category of installation	II
				Pollution Degree	2
				CONNECTIONS	
				Ethernet	RJ-45 (on terminals side)
				Inputs/Power Supply	Removable screw-terminals
				MECHANICAL SPECIFICATIONS	
				Material	Self-extinguish plastic
				IP Code	IP20
				Wiring	wires with diameter 0.8÷2.1 mm ² /AWG 14-18
				Tightening Torque	0.5 N m
				Mounting	in compliance with DIN rail standard EN-50022
				Weight	about 160g
				EMC (for industrial environments)	
				Immunity	EN 61000-6-2
				Emission	EN 61000-6-4

INSTALLATION INSTRUCTIONS

The device is suitable for fitting to DIN rails in vertical position. For optimum operation and long life follow these instructions:

When the devices are installed side by side it is necessary to separate them by at least 5 mm

Make sure that sufficient air flow is provided for the device avoiding to place raceways or other objects which could obstruct the ventilation slits. Moreover it is suggested to avoid that devices are mounted above appliances generating heat; their ideal place should be in the lower part of the panel. Install the device in a place without vibrations.

Moreover it is suggested to avoid routing conductors near power signal cables (motors, induction ovens, inverters, etc...) and to use shielded cable for connecting signals.

MAPPING MODBUS REGISTERS

Register Position	Description	Access
40002	Firmware [0]	RO
40003	Firmware [1]	RO
40004	Name [0]	R/W
40005	Name [1]	R/W
40007	Node ID	R/W
40011	System Flags	R/W
40013	Watchdog timer	R/W
40032	Digital Inputs	RO
40033	Digital Inputs Rise Latch	R/W
40034	Digital Inputs Fall Latch	R/W
40035	Freq. Digital Input 0	RO
40036	Freq. Digital Input 1	RO
40037	Freq. Digital Input 2	RO
40038	Freq. Digital Input 3	RO
40039	32 bit Counter Digital Input 0	R/W
40041	32 bit Counter Digital Input 1	R/W
40043	32 bit Counter Digital Input 2	R/W
40045	32 bit Counter Digital Input 3	R/W

LIGHT SIGNALLING

LED	COLOUR	STATE	DESCRIPTION
PWR	GREEN	ON	Device powered
		OFF	Device not powered
		BLINK	Watchdog alarm
STS	YELLOW	OFF	Device in RUN modality
		BLINK	Device in INIT modality
I n	RED	ON	Digital Inputs High Level (1)
		OFF	Digital Inputs Low Level (0)

MECHANICAL DIMENSIONS (mm)

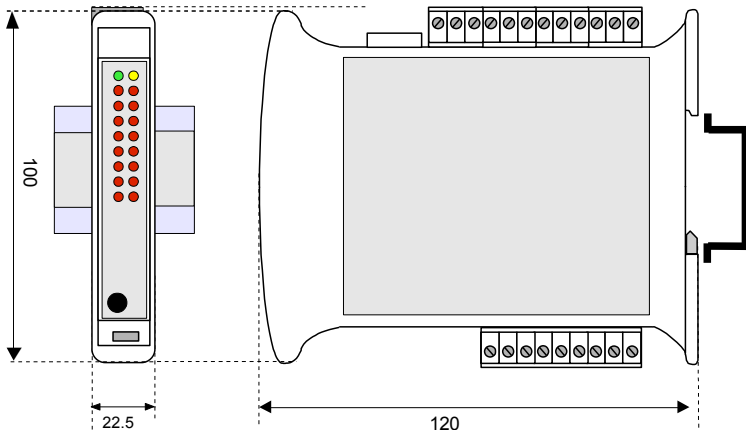

CONNECTIONS

POWER SUPPLY

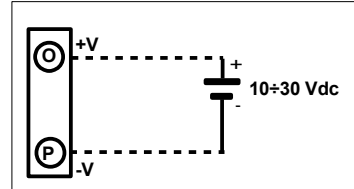

INIT

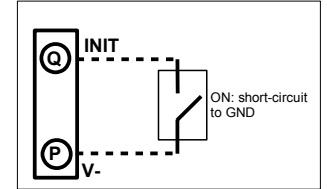

DIGITAL INPUTS

GROUP DIGITAL INPUTS 0÷7

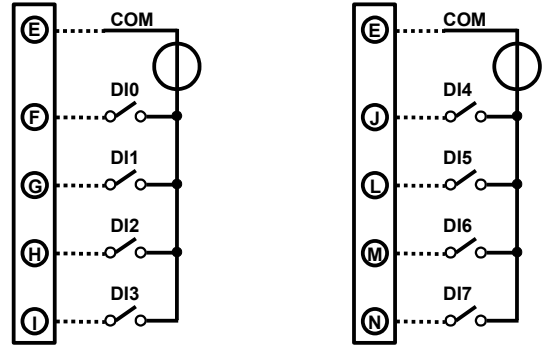

GROUP DIGITAL INPUTS 8÷15

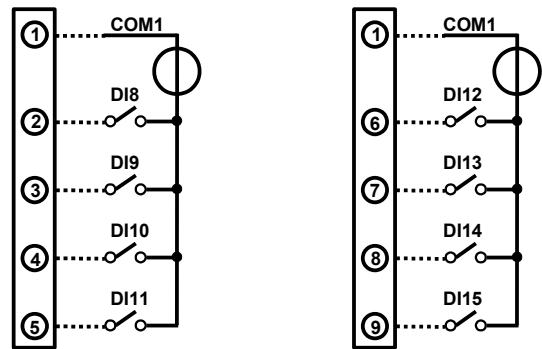

NOTES:

the input channels from 0 to 7 are not isolated between them .
the input channels from 8 to 15 are not isolated between them .
The group of input channels 0÷7 is isolated from the group of input channels 8÷15.

HOW TO ORDER

“ DAT 8148 “

Note: the device is provided with default configuration as:

IP address: 192.168.1.100

Modbus address: 1



The symbol reported on the product indicates that the product itself must not be considered as a domestic waste. It must be brought to the authorized recycle plant for the recycling of electrical and electronic waste. For more information contact the proper office in the user's city, the service for the waste treatment or the supplier from which the product has been purchased.