

Side-mounting Shaft type Incremental Rotary Encoder

■ Features

- Strong die cast structure against external impact
- Convenient structure for direct mounting on the frame
- Connector type
- Power supply : 5VDC, 12-24VDC ±5%

⚠ Please read "Caution for your safety" in operation manual before using.

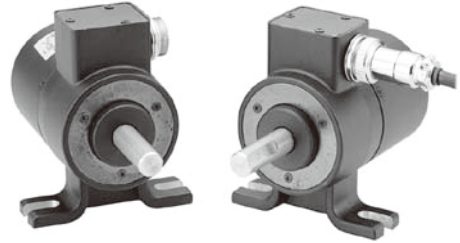

■ Ordering information

ENA	—	5000	—	2	—	N	—	24
Series	Pulse/1Revolution	Output phase	Output	Power supply				
Side-mounting shaft type (External diameter of shaft : ø10mm)	Refer to resolution	2 : A, B 3 : A, B, Z	T : Totem pole output N : NPN open collector output V : Voltage output	5 : 5VDC ±5% 24 : 12-24VDC ±5%				

※Standard : ENA--2-N-24

■ Specifications

Item	Side-mounting shaft type of incremental rotary encoder		
Resolution(P/R) ^{*1}	*1, *2, *5, 10, 12, 15, 20, 23, 25, 30, 35, 40, 45, 50, 60, 75, 100, 120, 150, 192, 200, 240, 250, 256, 300, 360, 400, 500, 512, 600, 800, 1000, 1024, 1200, 1500, 1800, 2000, 2048, 2500, 3000, 3600, 5000		
Electrical specification	Output phase	A, B phase(Option : A, B, Z phase)	
	Phase difference of output	Phase difference between A and B : $\frac{T}{4} \pm \frac{T}{8}$ (T=1cycle of A phase)	
	Control output	Totem pole output	• Low - Load current:Max. 30mA, Residual voltage : Max. 0.4VDC • High - Load current:Max. 10mA, Output voltage(Power voltage 5VDC):Min. (Power voltage-2.0)VDC, Output voltage(Power voltage 12-24VDC):Min. (Power voltage-3.0)VDC
		NPN open collector output	Load current : Max. 30mA, Residual voltage : Max. 0.4VDC
		Voltage output	Load current : Max. 10mA, Residual voltage : Max. 0.4VDC
	Response time (Rise/Fall)	Totem pole output	Max. 1μs
		NPN open collector output	
		Voltage output	
	Max. Response frequency	300kHz	
	Power supply	• 5VDC ±5%(Ripple P-P : Max. 5%) • 12-24VDC ±5%(Ripple P-P : Max. 5%)	
Current consumption	Max. 80mA(disconnection of the load)		
Insulation resistance	Min. 100MΩ(at 500VDC megger between all terminals and case)		
Dielectric strength	750VAC 50/60Hz for 1 minute(Between all terminals and case)		
Connection	Connector type		
Mechanical specification	Starting torque	Max. 70gf·cm(0.007N·m)	
	Moment of inertia	Max. 80g·cm ² (8×10 ⁻⁶ kg·m ²)	
	Shaft loading	Radial : 10kgf, Thrust : 2.5kgf	
	Max. allowable revolution ^{※2}	5000rpm	
Vibration	1.5mm amplitude or 300m/s ² at frequency of 10 to 55Hz(for 1 min.) in each of X, Y, Z directions for 2 hours		
Shock	Approx. Max. 75G		
Environment	Ambient temperature	-10 to 70°C, storage : -25 to 85°C	
	Ambient humidity	35 to 85%RH, storage : 35 to 90%RH	
Protection	IP50(IEC standard)		
Cable	ø5, 5-wire, Length : 2m, Shield cable (AWG 24, Core diameter : 0.08mm, Number of cores : 40, Insulator out diameter : ø1)		
Accessory	ø10mm coupling		
Approval	CE		
Unit weight	Approx. 345g		

※1: '*' pulse is only for A, B phase

※2: Make sure that. Max response revolution should be lower than or equal to max. allowable revolution when selecting the resolution.

$$[\text{Max. response revolution}(\text{rpm})] = \frac{\text{Max. response frequency}}{\text{Resolution}} \times 60 \text{ sec}$$

※Environment resistance is rated at no freezing or condensation.

(A) Photo electric sensor

(B) Fiber optic sensor

(C) Door/Area sensor

(D) Proximity sensor

(E) Pressure sensor

(F) Rotary encoder

(G) Connector/Socket

(H) Temp. controller

(I) SSR/ Power controller

(J) Counter

(K) Timer

(L) Panel meter

(M) Tacho/ Speed/ Pulse meter

(N) Display unit

(O) Sensor controller

(P) Switching mode power supply

(Q) Stepper motor& Driver&Controller

(R) Graphic/ Logic panel

(S) Field network device

(T) Software

(U) Other

ENA Series

Control output diagram

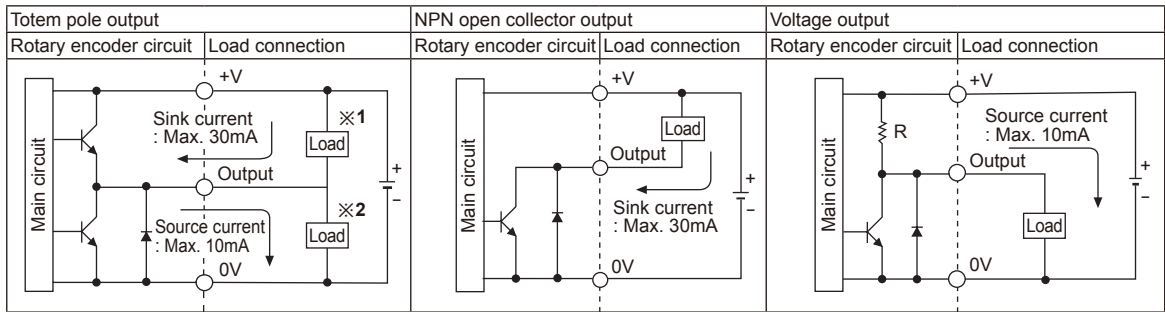

- The output circuits of A, B phase (Option : A, B, Z phase) are the same.
- Totem pole output type can be used for NPN open collector type(※1) or voltage output type(※2).

Output waveform

- Totem pole output / NPN open collector output / Voltage output

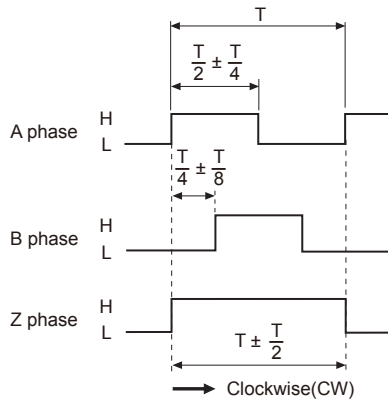

- ※Z phase output is option.
- ※CW : Right turn as from the shaft

Connections

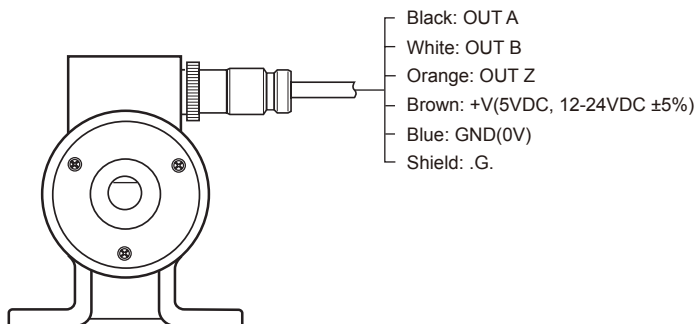

Pin No	Cable color	Function
①	Black	OUT A
②	White	OUT B
③	Brown	+V
④	Blue	GND
①	Black	OUT A
②	White	OUT B
③	Orange	OUT Z
④	Brown	+V
⑤	Blue	GND

- ※Z phase output is option.
- ※Unused wires must be insulated.
- ※The metal case and shield cable of encoder must be grounded(F.G.).

Incremental Side-Mounting type

■ Dimensions

(unit: mm)

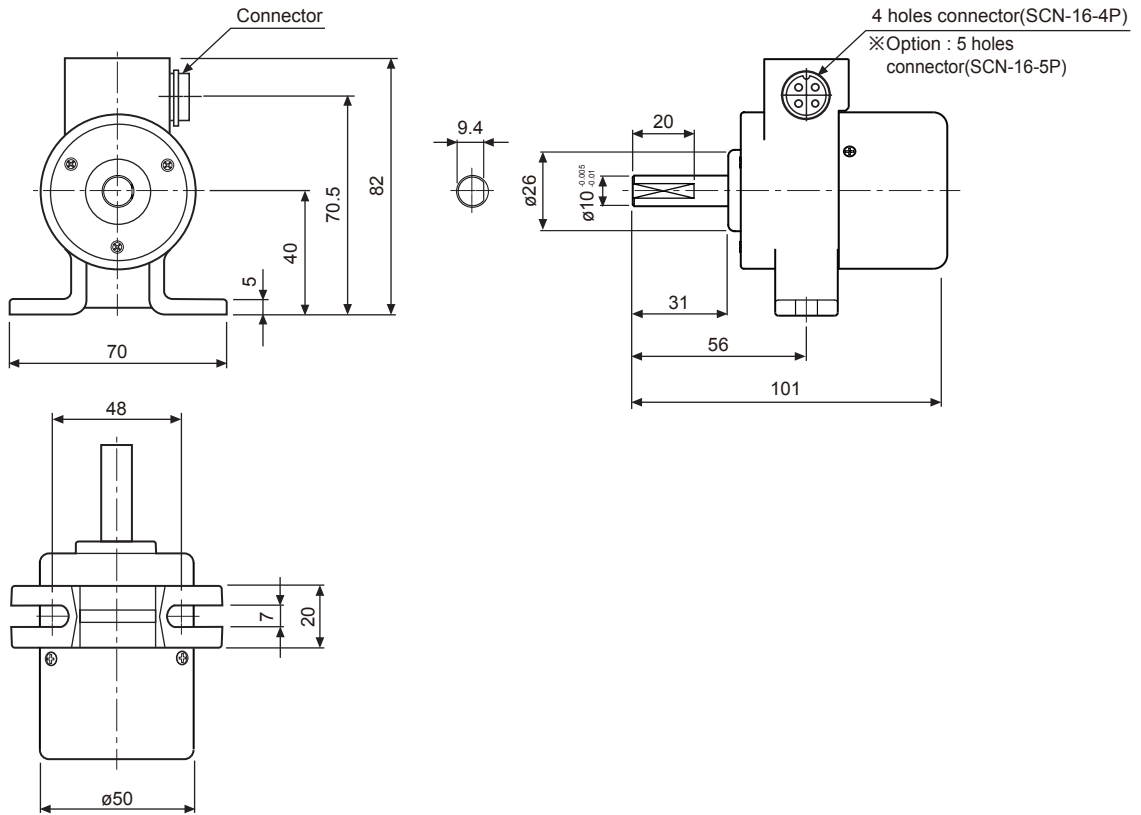

◎ Connector cable

● ENA(2m, 4-wire)

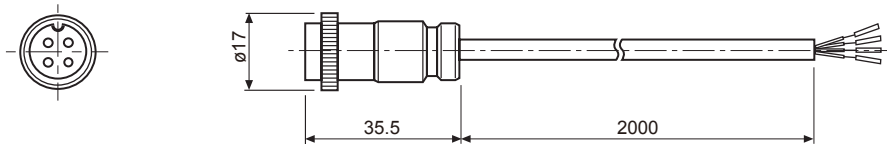

● ENA(2m, 5-wire) (Option)

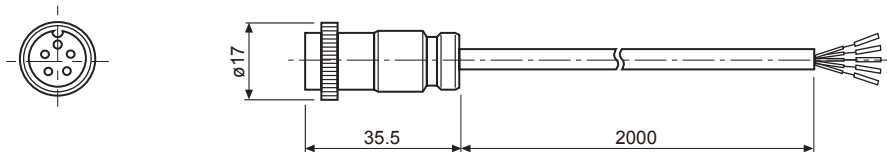

◎ Coupling(ENA)

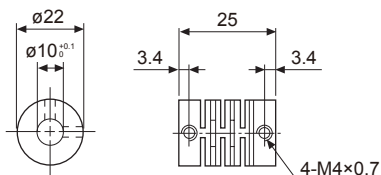

- Parallel misalignment : Max. 0.25mm
- Angular misalignment : Max. 5°
- End-play : Max. 0.5mm
- ※For parallel misalignment, angular misalignment, end-play terms, refer to the F-78 page.

(A)
Photo
electric
sensor

(B)
Fiber
optic
sensor

(C)
Door/Area
sensor

(D)
Proximity
sensor

(E)
Pressure
sensor

(F)
Rotary
encoder

(G)
Connector/
Socket

(H)
Temp.
controller

(I)
SSR/
Power
controller

(J)
Counter

(K)
Timer

(L)
Panel
meter

(M)
Tacho/
Speed/
Pulse
meter

(N)
Display
unit

(O)
Sensor
controller

(P)
Switching
mode power
supply

(Q)
Stepper
motor&
Driver&Controller

(R)
Graphic/
Logic
panel

(S)
Field
network
device

(T)
Software

(U)
Other