

2-Phase Closed-loop Stepper Motor Driver



AiS-D Series CATALOG

For your safety, read and follow the considerations written in the instruction manual, other manuals and Autonics website.

The specifications, dimensions, etc. are subject to change without notice for product improvement. Some models may be discontinued without notice.

Features

- Closed-loop system with real-time position control
- High speed & high torque drive without missing steps
- Easy operation setting with external adjuster (Gain, Speed filter, In-position, Resolution)
- Built-in brake type motors available (AiS-D-B Series)

Ordering Information

This is only for reference, the actual product does not support all combinations.. For selecting the specified model, follow the Autonics website. Select a model that matches the ordering information of the motor and the driver.

AiS - **D** - **①** **②** **③** - **④**

① Frame size

Number: Frame size (Unit: mm)

③ Encoder resolution

	□ 20 / 28 / 35 mm	□ 42 / 56 / 60 mm
A	4,000 PPR (1,000 PPR × 4)	10,000 PPR (2,500 PPR × 4)
B	16,000 PPR (4,000 PPR × 4)	-

② Axial length

S: Short
M: Medium
L: Long

④ Motor type

No mark: Standard type
B: Built-in brake type

Product Components

- Product
- Instruction manual
- Power connector
- I/O connector
- Brake connector (AiS-D-B Series)

Specifications

Model	AiS-D-20□A	AiS-D-28□B	AiS-D-35□B
Power supply	24 VDC± ±10%		
Max. RUN power ⁰¹⁾	≤ 50 W	≤ 60 W	
Stop power ⁰²⁾	≤ 10 W		
Max. RUN current ⁰³⁾	0.6 A / Phase	1.0 A / Phase	1.2 A / Phase
Stop current	25% or 50% (factory default: 50%) of max. RUN current		
Resolution	500 (factory default), 1000, 1600, 2000, 3600, 4000, 5000, 6400, 7200, 10000 PPR	500 (factory default), 1000, 1600, 2000, 3600, 5000, 6400, 7200, 10000, 16000 PPR	

Model	AiS-D-42□A-□	AiS-D-56□A-□	AiS-D-60□A-□
Power supply	24 VDC± ±10%		
Max. RUN power ⁰¹⁾	≤ 60 W	≤ 120 W	≤ 240 W
Stop power ⁰²⁾	S: ≤ 7 W (≤ 16 W) M: ≤ 7.5 W (≤ 16 W) L: ≤ 8 W (≤ 17 W)	S: ≤ 9.5 W (≤ 23 W) M: ≤ 10 W (≤ 23 W) L: ≤ 11 W (≤ 25 W)	S: ≤ 12 W (≤ 25 W) M: ≤ 13 W (≤ 26 W) L: ≤ 14 W (≤ 26 W)
Max. RUN current ⁰³⁾	1.7 A / Phase		3.5 A / Phase
Stop current	25% or 50% (factory default: 50%) of max. RUN current		
Resolution	500 (factory default), 1000, 1600, 2000, 3200, 3600, 5000, 6400, 7200, 10000 PPR		

01) When changing the load rapidly, instantaneous peak current may increase. The capacity of power supply should be over 1.5 to 2 times of max. RUN power.

02) Based on ambient temp. 25°C, ambient humi. 55%RH, stop current 50%. The value in the bracket indicates built-in brake type.

03) RUN current varies depending on the input RUN frequency and max. RUN current at the moment varies also.

Run method	2-phase bipolar closed-loop control method
Speed filter	Disable, 2, 4, 6, 8, 10, 20, 40, 60 (factory default), 80, 100, 120, 140, 160, 180, 200 ms
Control Gain	(P Gain, I Gain)=(1, 1), (2, 1), (3, 1), (4, 1), (5, 1), (1, 2), (2, 2), (3, 2), (4, 2), (5, 2), (1, 3), (2, 3), (3, 3), (4, 3), (5, 3)
Max. rotation speed	3000 rpm
In-Position	Fast Response: 0 (factory default) to 7, Accurate Response: 0 to 7
Rotation direction	CW (factory default), CCW
Input	CW/CCW (RUN pulse), Servo ON/OFF, Alarm Reset (Photocoupler input)
Output	In-Position, Alarm Out (Photocoupler output), Encoder Signal (A, A̅, B, B̅, Z, Z̅, Line driver output), Brake (at supplying: 0.2 sec 24 VDC±, normal status: 11.5 VDC± ±10%)
Pulse input method	1 pulse, 2 pulse (factory default)
Pulse input voltage	CW, CCW-[H]: 4 - 8 VDC±, [L]: 0 - 0.5 VDC±, Servo ON/OFF, Alarm Reset-[H]: 24 VDC±, [L]: 0 - 0.5 VDC±
Max. input pulse frequency	□ 20 / 28 / 35 mm: CW, CCW: 800 kHz □ 42 / 56 / 60 mm: CW, CCW: 500 kHz
Pulse width	CW, CCW: Input Pulse Frequency Duty 50% (□ 20 mm: ≥ 2 μs, □ 28 / 35 mm: ≥ 1.25 μs) Servo ON/OFF: ≥ 1 ms Alarm Reset: ≥ 20 ms
Rise fall time	CW, CCW: < 0.5 μs

Input resistance	220 Ω (CW, CCW), 10 kΩ (Servo ON/OFF, Alarm Reset)
Insulation resistance	≥ 100 MΩ (500 VDC± megger)
Dielectric strength	1,000 VAC~ 60 Hz for 1 minute
Vibration	1.5 mm double amplitude at frequency 10 to 55 Hz (for 1 minute) in each X, Y, Z direction for 2 hours
Shock	300 m/s ² (≈ 30 G) in each X, Y, Z direction for 3 times
Ambient temp.	□ 20 / 28 / 35 mm: 0 to 50°C, storage: -20 to 70°C (no freezing or condensation) □ 42 / 56 / 60 mm: 0 to 50°C, storage: -10 to 60°C (no freezing or condensation) Built-in brake type: 0 to 50°C, storage: -20 to 70°C (no freezing or condensation)
Ambient humi.	35 to 85%RH, storage: 10 to 90%RH (no freezing or condensation)
Protection rating	IP20 (IEC standard)
Approval	CE ENEC
Unit weight (packaged)	≈ 290 g (≈ 400 g)

Dimensions

• Unit: mm, For the detailed drawings, follow the Autonics website.

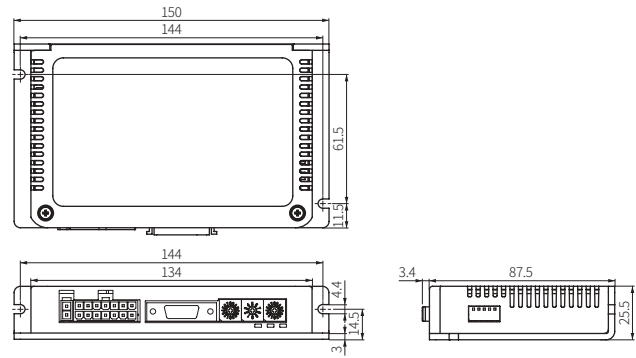

Unit Descriptions

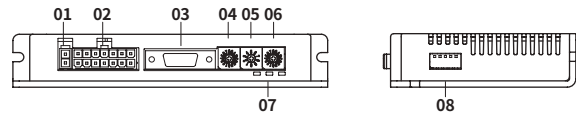

01. Power connector

02. Motor + Encoder connector

03. I/O connector

04. Speed filter / Control Gain setting rotary switch

05. Resolution setting rotary switch

06. In-Position setting rotary switch

07. Status indicator

08. Function selection DIP switch

Sold Separately

- Power cable: CJ-PW-□
- Motor + Encoder cable: C1D14M-□ (fixed type), C1DF14M-□ (flexible type)
- I/O cable: CO20-MP□-R (specifications: AiS TAG)

Sold Separately : Power Cable

■ CJ-PW-□

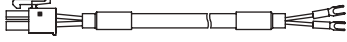

- Recommended to use ferrite core at both ends of the cable.
- The model name is 010, 020 which indicates the cable length.
E.g.) CJ-PW-010: 1 m power cable

Sold Separately : Motor + Encoder Cable

■ Fixed type: C1D14M-□, Flexible type: C1DF14M-□



- Recommended to use ferrite core at both ends of the cable.
- The model name is 1, 2, 3, 5, 7, 10, 15, 20 which indicates the cable length.
E.g.) C1DF14M-10: 10 m flexible type, Motor + Encoder cable

Sold Separately : I/O Cable

■ CO20-MP□-R (specifications: AiS TAG)

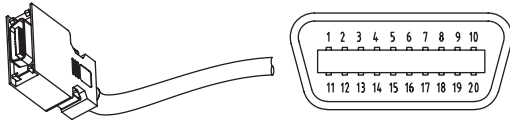

Pin	Function (Name TAG)	Cable color	Dot line color-number
1	CW+	Yellow	Black-1
2	CW-		Red-1
3	CCW+		Black-2
4	CCW-		Red-2
5	Servo ON/OFF+		Black-3
6	Servo ON/OFF-		Red-3
7	Alarm Out+		Black-4
8	Alarm Out-		Red-4
9	Alarm Reset+		Black-5
10	Alarm Reset-		Red-5
11	In-Position+	White	Black-1
12	In-Position-		Red-1
13	Brake+		Black-2
14	Brake-		Red-2
15	Encoder A		Black-3
16	Encoder \bar{A}		Red-3
17	Encoder B		Black-4
18	Encoder \bar{B}		Red-4
19	Encoder Z		Black-5
20	Encoder \bar{Z}		Red-5

- Recommended to use ferrite core at both ends of the cable.
- The model name is 010, 020, 030, 050, 070, 100, 150, 200 which indicates the cable length.
E.g.) CO20-MP070-R: 7 m I/O cable