

V20 Eyesight

Vision system for complex image-processing applications, C-mount



PRODUCT HIGHLIGHTS

- Complete image-processing package with robust and flexible hardware, 1.3 mega pixel
- Programming via drag & drop of function blocks
- Complex, iterative linkage of individual inspections
- Image processing can be simulated on the PC without camera
- Image and result visualisation in inspection mode
- Script interpreter for advanced user functions

Optical data		Functions	
Resolution	1280 x 1024 pixels	Number of inspection programmes	No limitation (max. ca. 40 MB)
CMOS	1/1.8", monochrome or colour	Functions	All function blocks for object measurement, position determination/tracking, sequence control, data and image transfer, contour inspection, subprogrammes, script interpreter.
Integrated lens, focal length	C-mount	Properties	See overview of commands
Adjustment range	Dependent on lens	Typical cycle times	Dependent on inspection programme
Integrated illumination	None		
Minimum field of view, X x Y	Dependent on lens		
Electrical data		Mechanical data	
Operating voltage, +U _B	18 ... 26.4V DC ¹	Dimensions	65 x 45 x 45 mm (without plug)
Current consumption (without illumination and I/O)	≤ 120 mA	Enclosure rating	IP 65 ²
Current consumption (without I/O)	≤ 200 mA	Material, housing	Aluminium, plastic
Protective circuits	Reverse-polarity protection, U _B / short-circuit protection of all outputs	Material, front screen	Plastic
Power On Delay	Ca. 13 s after Power on	Ambient temperature: operation	0 ... +50 °C ³
Outputs	PNP	Ambient temperature: storage	-20 ... +60 °C ³
Max. output current (per output)	50 mA, 100 mA (pin 12)	Weight	Ca. 160 g
Inputs	PNP High > U _B -1 V, Low < 3 V	Plug connections	Supply and I/O M12, 12-pin Ethernet M12, 4-pin Data M12, 5-pin
Input resistance	> 20 kΩ	Vibration and impact resistance	EN 60947-5-2
Interfaces	Ethernet (LAN), RS422, RS232		
Inputs/outputs	2 inputs, 4 outputs, 4 selectable inputs/outputs		

¹ Max. ripple < 5V_{SS} ² With LPT45 C-mount protective casing ³ 80 % air humidity, non-condensing

Product variant	Part number	Article number
Monochrome	V20-EYE-A2-C	537-91007
Colour	V20C-EYE-A2-C	537-91015

V20 vision system

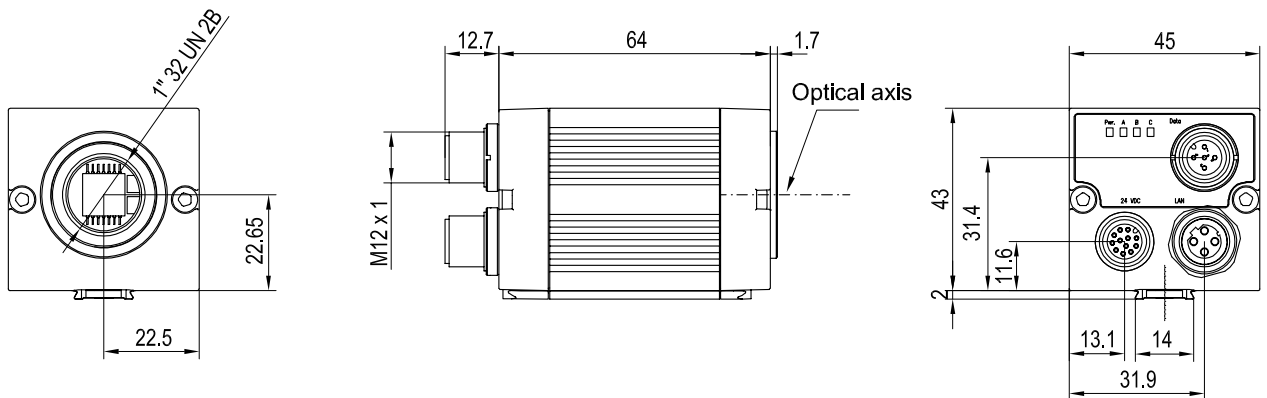

153-00912

4

Lens



	LO C 8	LO C 12	LO C 16	LO C 25	LO C 35	LO C 50	LO C 75
Focal length	8 mm	12 mm	16 mm	25 mm	35 mm	50 mm	75 mm
Article number	526-51513	526-51514	526-51515	526-51516	526-51525	526-51113	526-51116

Accessories

Connection cables	From Page A-38
Illumination	From Page A-30
Lenses	From Page A-27
Brackets	From Page A-14
Interface accessories	From Page A-42