

VISOR® V10 Code Reader

Standard vision sensor for code reading, 25 mm



EtherNet/IP™

PRODUCT HIGHLIGHTS

- Can be used for all common 2D codes (ECC 200 data matrix) and common 1D bar codes
- Reliable detection of even poorly readable codes under difficult ambient conditions
- Comprehensive tools for flexible and easy connection to PC and PLC environments

Optical data		Functions	
Resolution	736 x 480 pixels	Number of jobs / detectors	8 / 2
CMOS	1/3", monochrome	Detectors	Bar code / data code
Integrated lens, focal length	25 mm, adjustable focal position	Properties	Bar code: reading of 1D bar codes, EAN, UPC, RSS, 2/5 Interleaved, 2/5 Industrial, Code 32, Code 39, Code 93, Code 128, GS1, Pharmacode, Codabar; data code: reading of 2D codes, ECC200, QR code, PDF 417, ECC200 GS1
Adjustment range	140 mm to infinity	Typical cycle times	Typ. 30 ms bar code Typ. 40 ms data code
Integrated illumination	White, red, infrared LEDs		
Minimum field of view, X x Y	18 x 14 mm ²		
Electrical data		Mechanical data	
Operating voltage, +U _b	18 ... 26.4V DC ¹	Dimensions	65 x 45 x 45 mm (without plug)
Current consumption (without illumination and I/O)	≤ 120 mA	Enclosure rating	IP 67
Current consumption (without I/O)	≤ 200 mA	Material, housing	Aluminium, plastic
Protective circuits	Reverse-polarity protection, U _b / short-circuit protection of all outputs	Material, front screen	Plastic
Power On Delay	Ca. 13 s after Power on	Ambient temperature: operation	0 ... +50 °C ²
Outputs	PNP / NPN (switchable)	Ambient temperature: storage	-20 ... +60 °C ²
Max. output current (per output)	50 mA, 100 mA (pin 12)	Weight	Ca. 160 g
Inputs	PNP/NPN High > U _b -1V, Low < 3V	Plug connections	Supply and I/O M12, 12-pin Ethernet M12, 4-pin Data M12, 5-pin
Input resistance	> 20 kOhm	Vibration and impact resistance	EN 60947-5-2
Encoder input	High > 4V		
Interfaces	Ethernet (LAN), RS422, RS232, EtherNet/IP, PROFINET, SensoWeb		
Inputs/outputs	2 inputs, 4 outputs, 4 selectable inputs/outputs		

¹ Max. ripple < 5 V_{SS} ² 80 % air humidity, non-condensing

Illumination	Depth of field	Part number	Article number
White	Normal	V10-CR-S2-W25	535-91088
Red	Normal	V10-CR-S2-R25	535-91089
Infrared	Normal	V10-CR-S2-I25	535-91090

VISOR® vision sensor

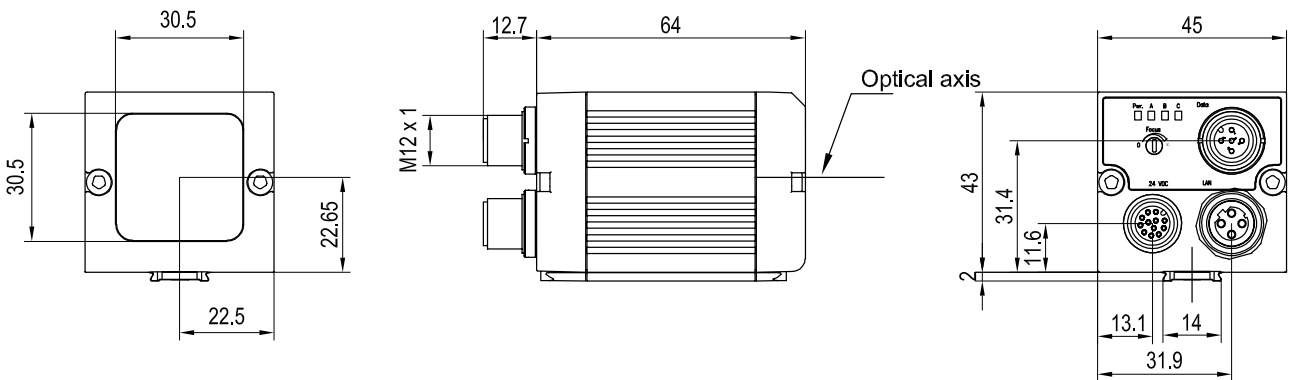

153-00911

5

Field of view

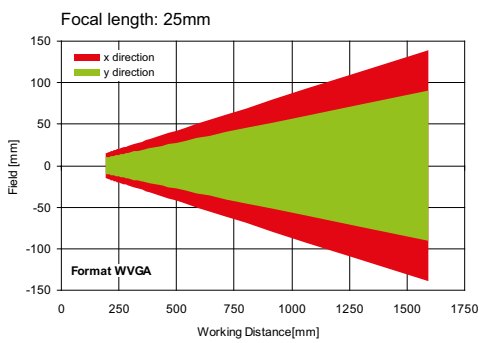

155-01424

Depth of field: normal

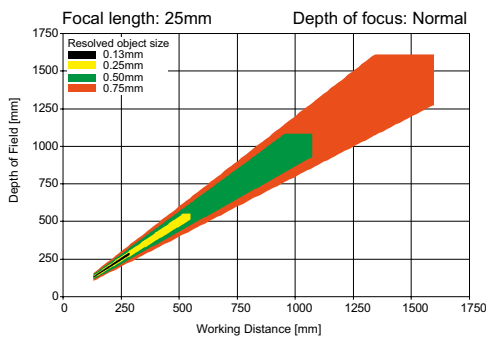

155-01412

Accessories

Connection cables	From Page A-38
Illumination	From Page A-30
Brackets	From Page A-14
Interface accessories	From Page A-42